



HSE

Occupational Health & Safety
and Environmental Protection unit

FIRIA

FDS Modelling of a Large Underground Cavern of CERN's LHC Accelerator Complex

Berta Rubio Pascual

on behalf of Giordana Gai, Oriol Rios, and Saverio la Mendola

10 – 09 – 2020

CERN

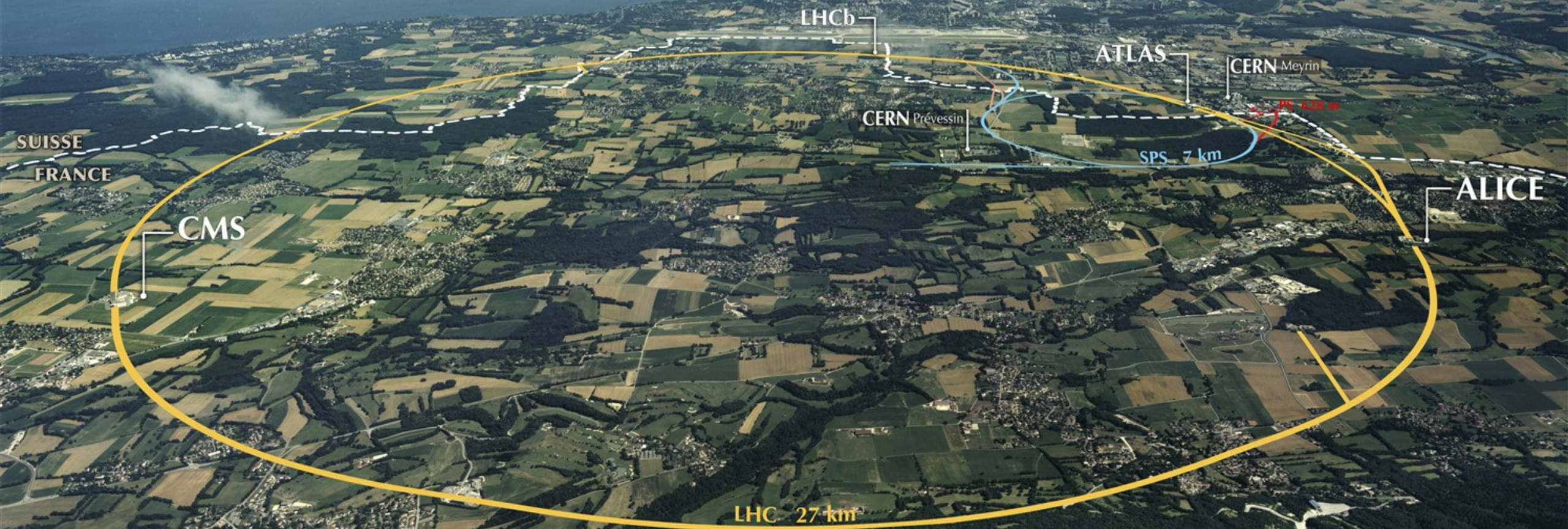

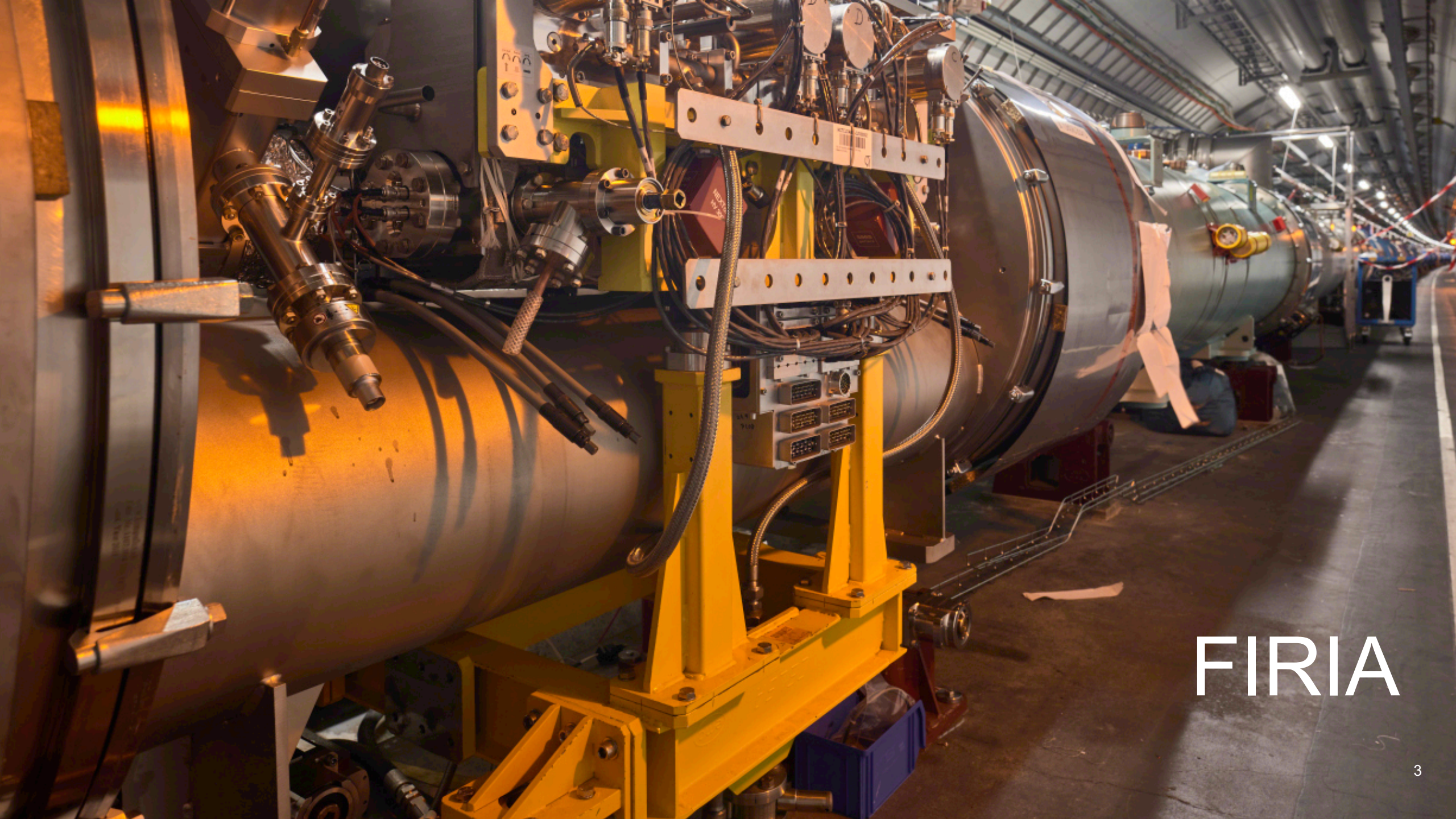

FIRIA

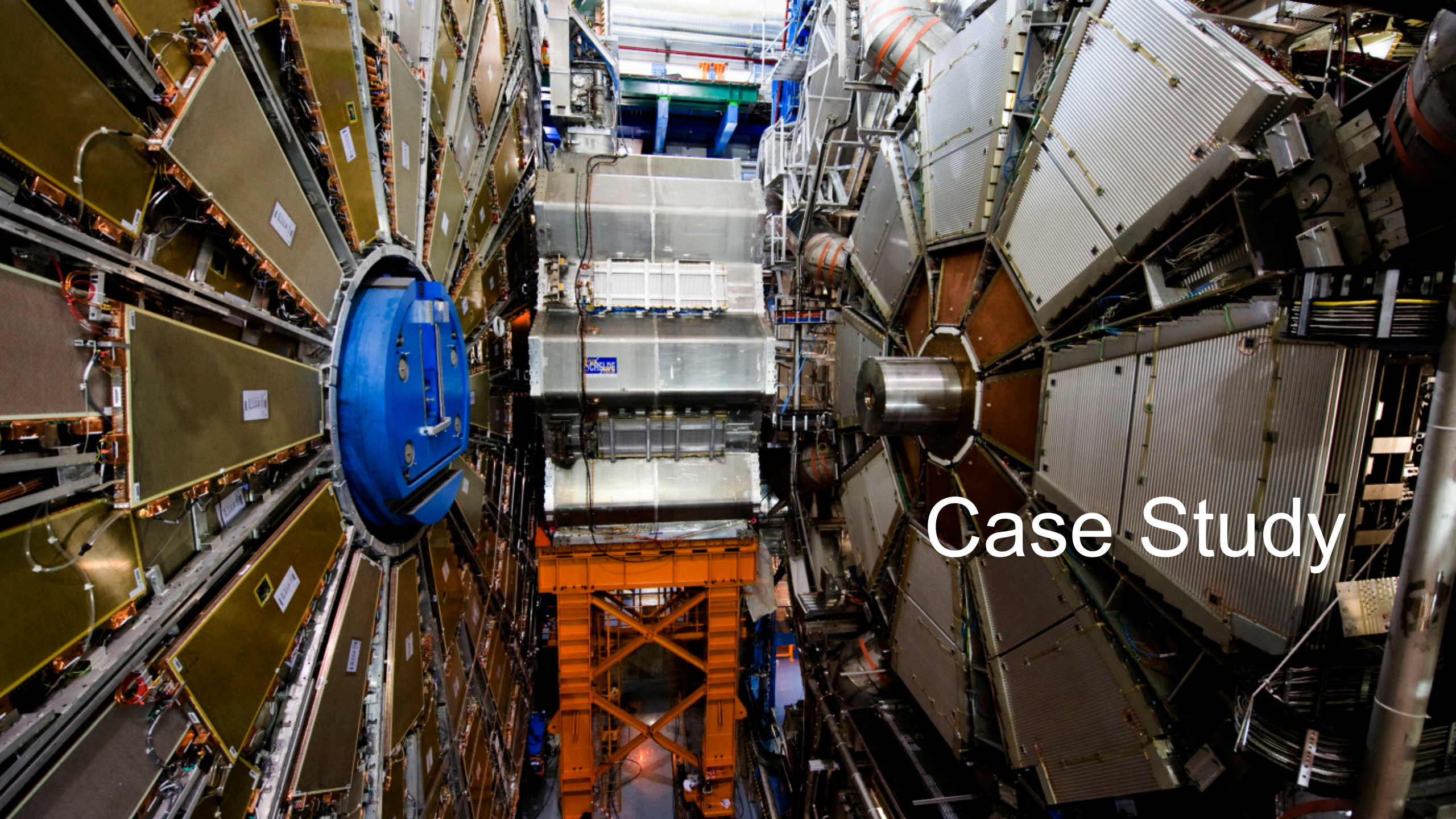

Case Study

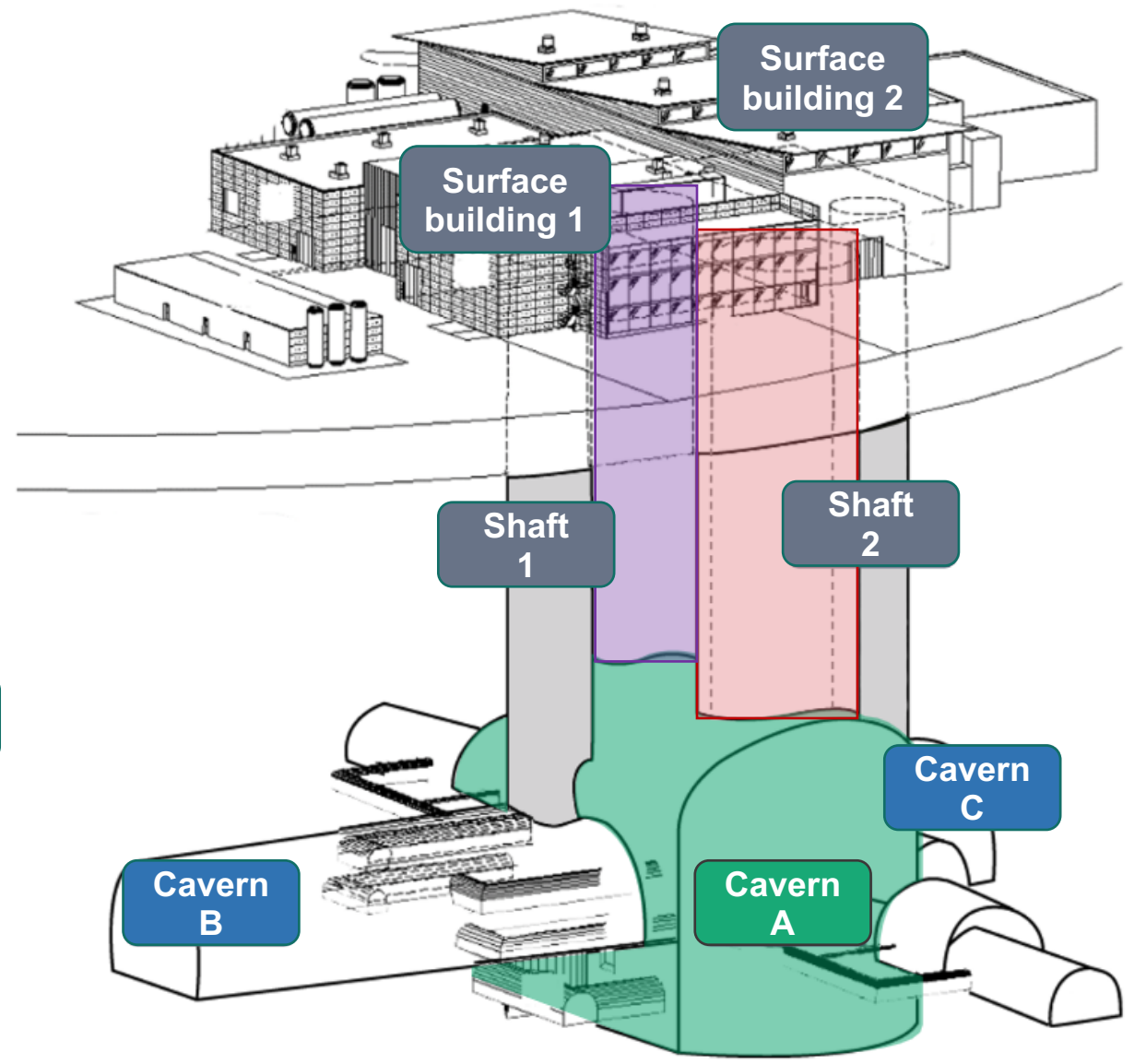
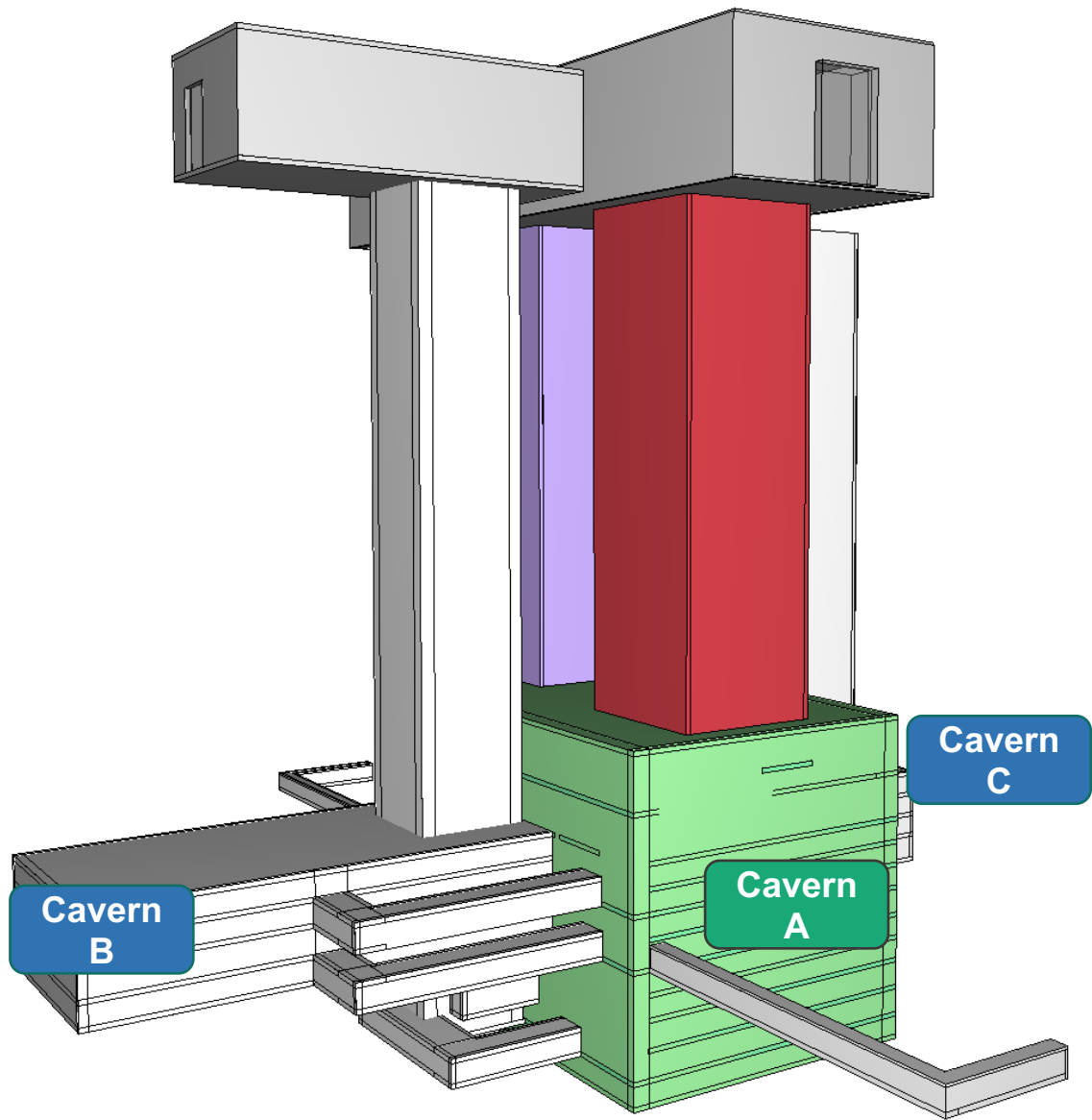

FDS Model

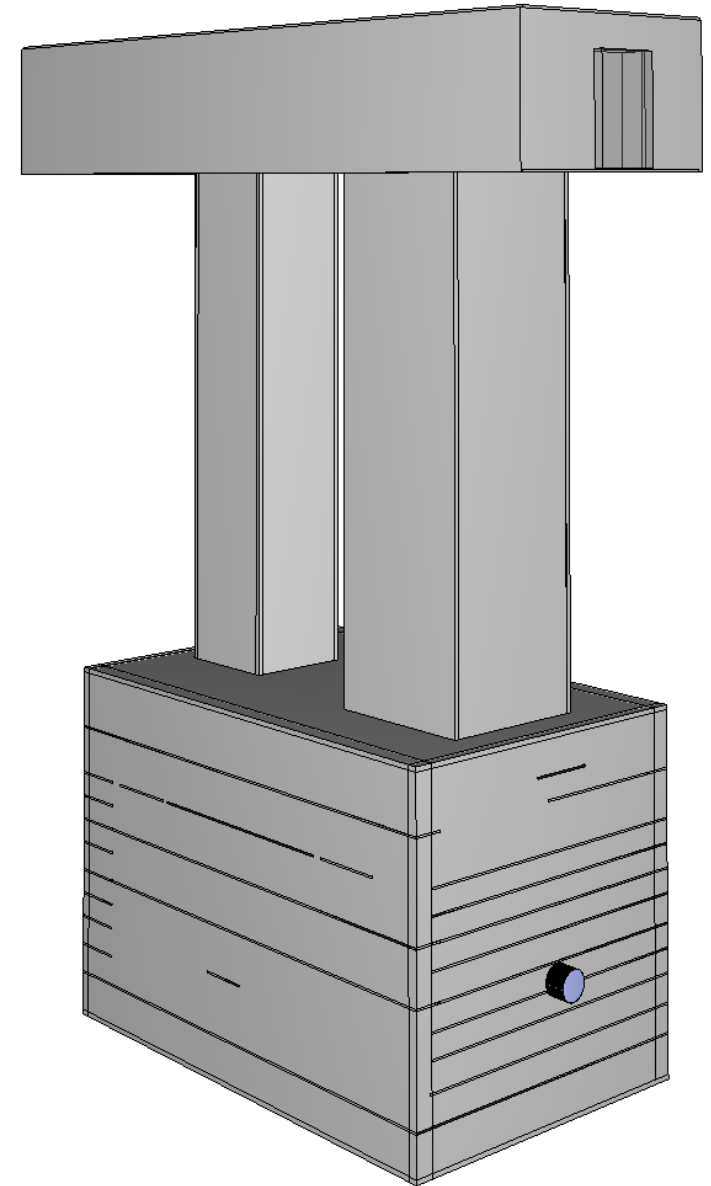
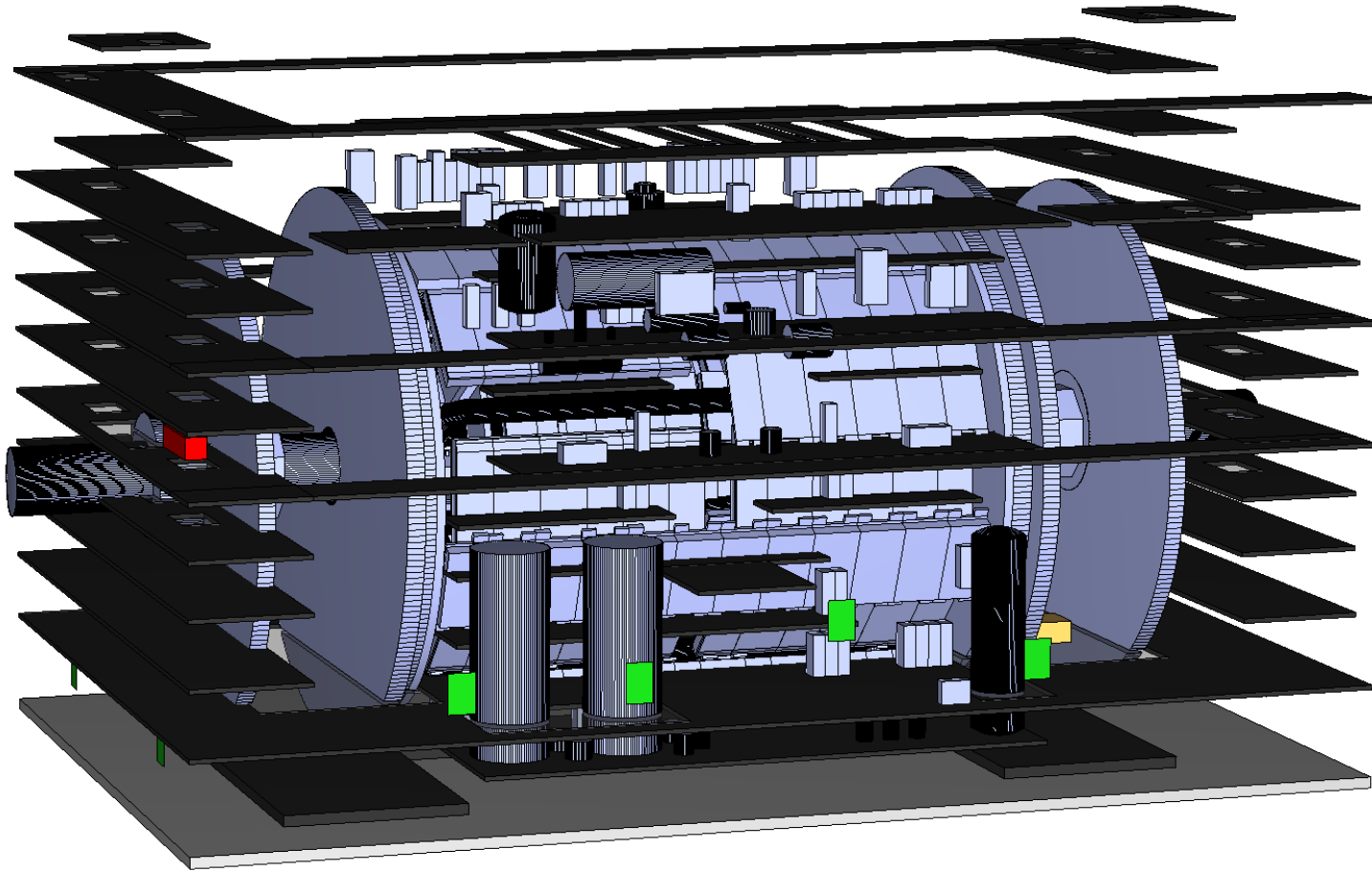

FDS Model

SHUT DOWN

RUN

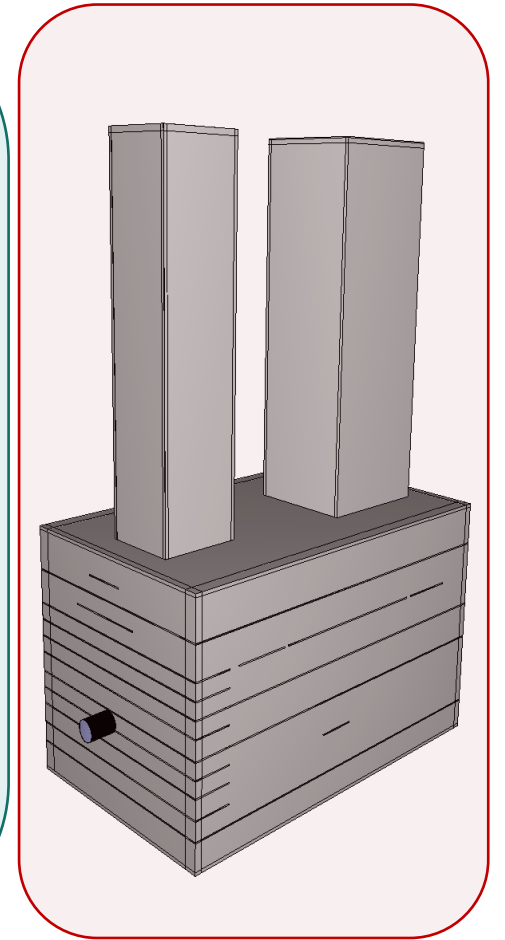
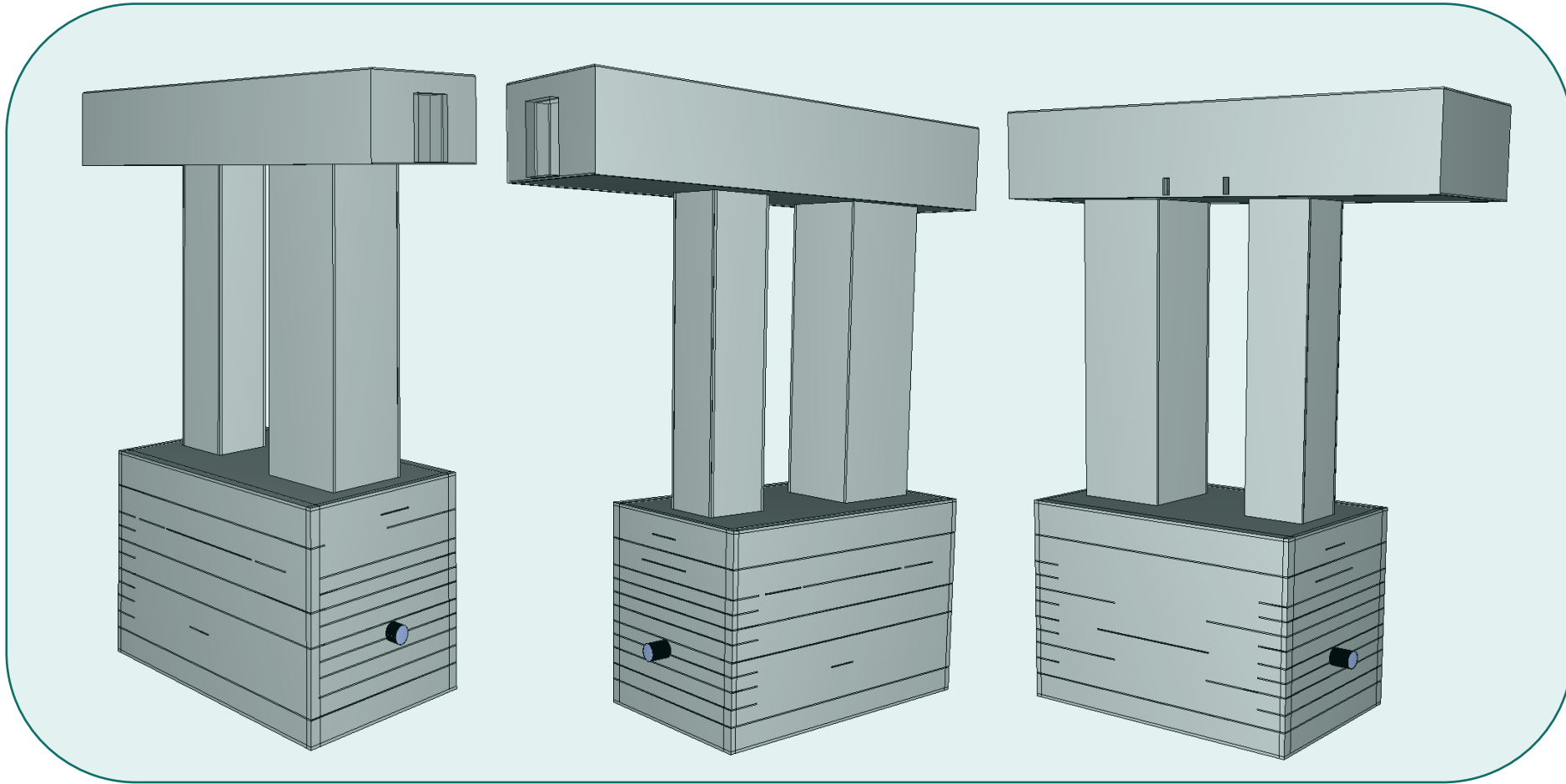

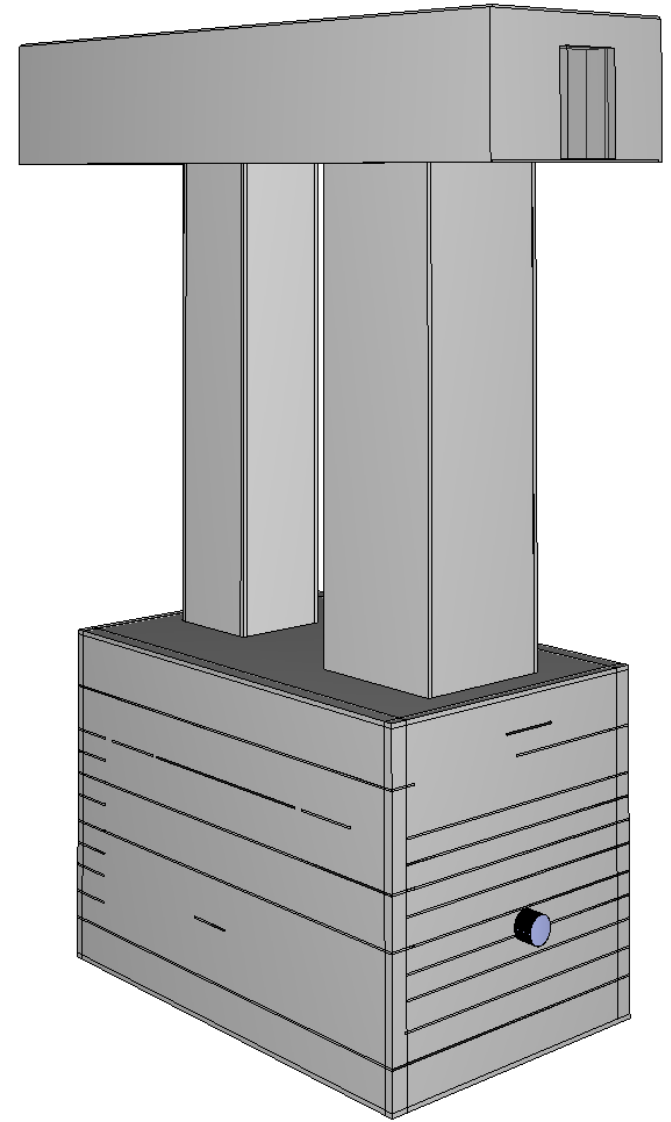

Results

Normal ventilation on



+ XX XXX m³/h
- YY YYY m³/h

Normal ventilation off



+ 0 m³/h
- 0 m³/h

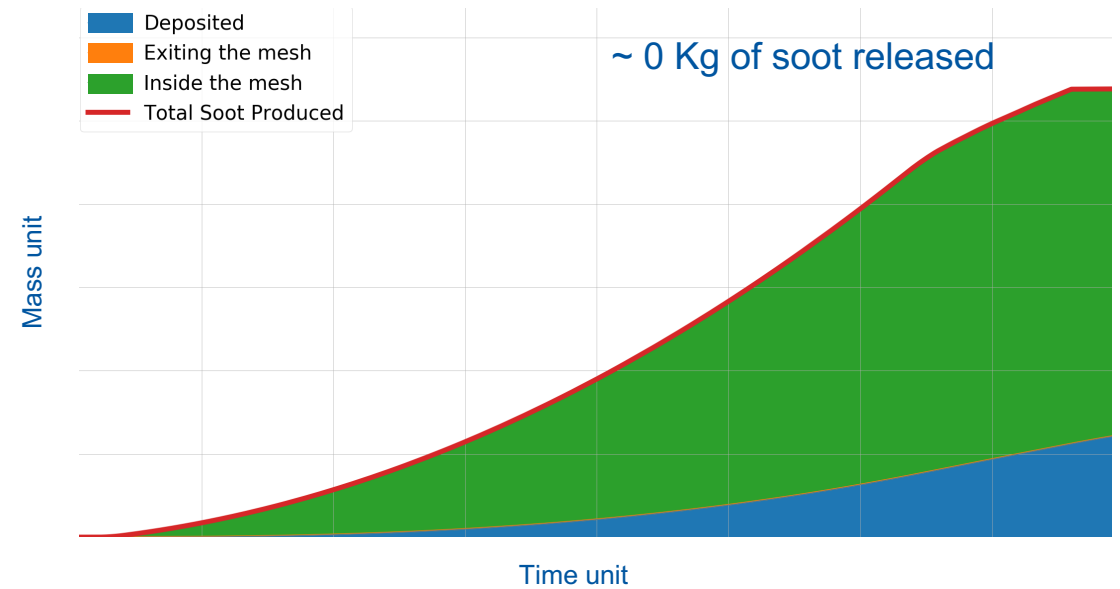
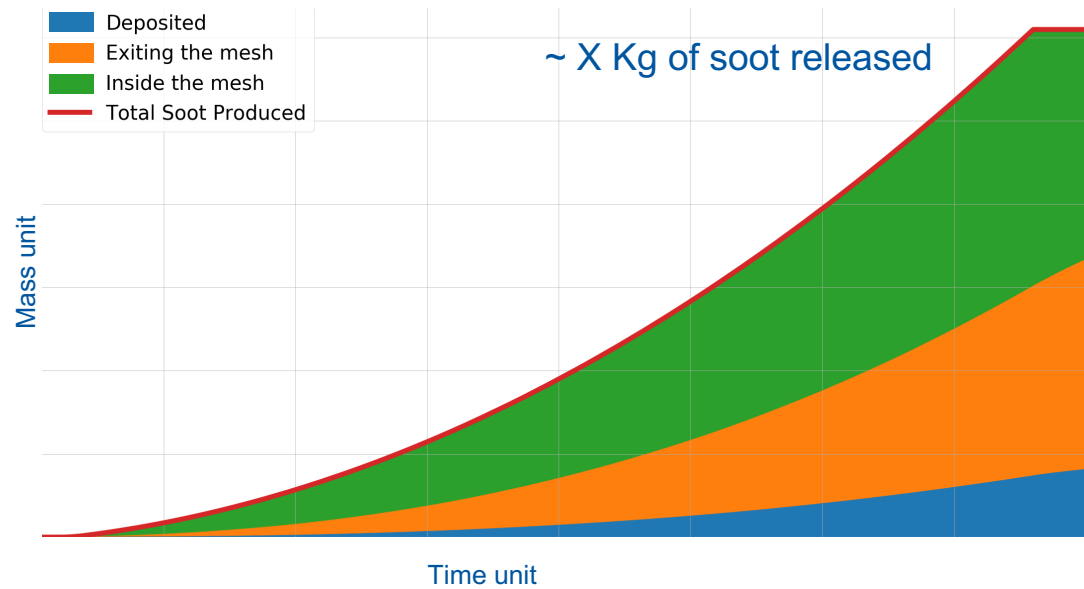





www.cern.ch